

340, 20013500001-20030100000

SPARE PARTS LIST

Q



Up to 991499999 (1999)

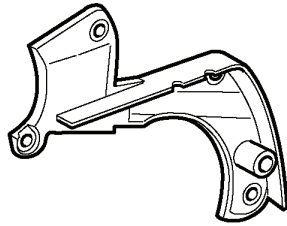

503 89 07-02



Up to 010604200 (340) (2001)
Up to 010602850 (345) (2001)
Up to 010702450 (350) (2001)

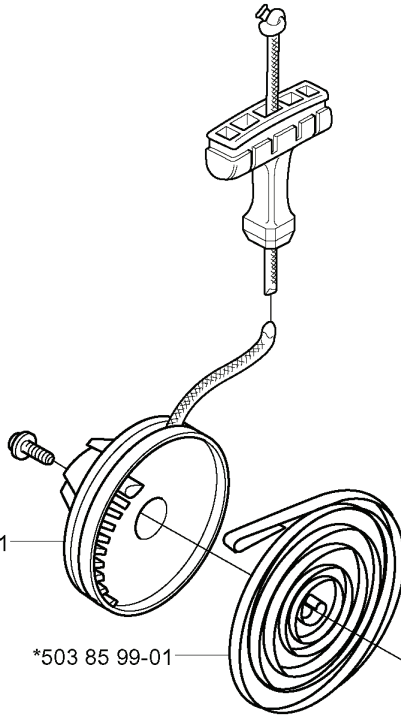

*503 87 63-01

*503 85 99-01



Up to 000601101 (345) (2000)



503 92 60-01 (x2)

REF.	PART NO.	DESCRIPTION	REMARK	QTY.	KIT
503 87 63-01	503876301	STARTER PULLEY		1	
503 89 07-02	503890702	HUB CAP		1	
503 85 99-01	503859901	RECOIL SPRING		1	
503 92 60-01	503926001	COVER PLATE		1	

G

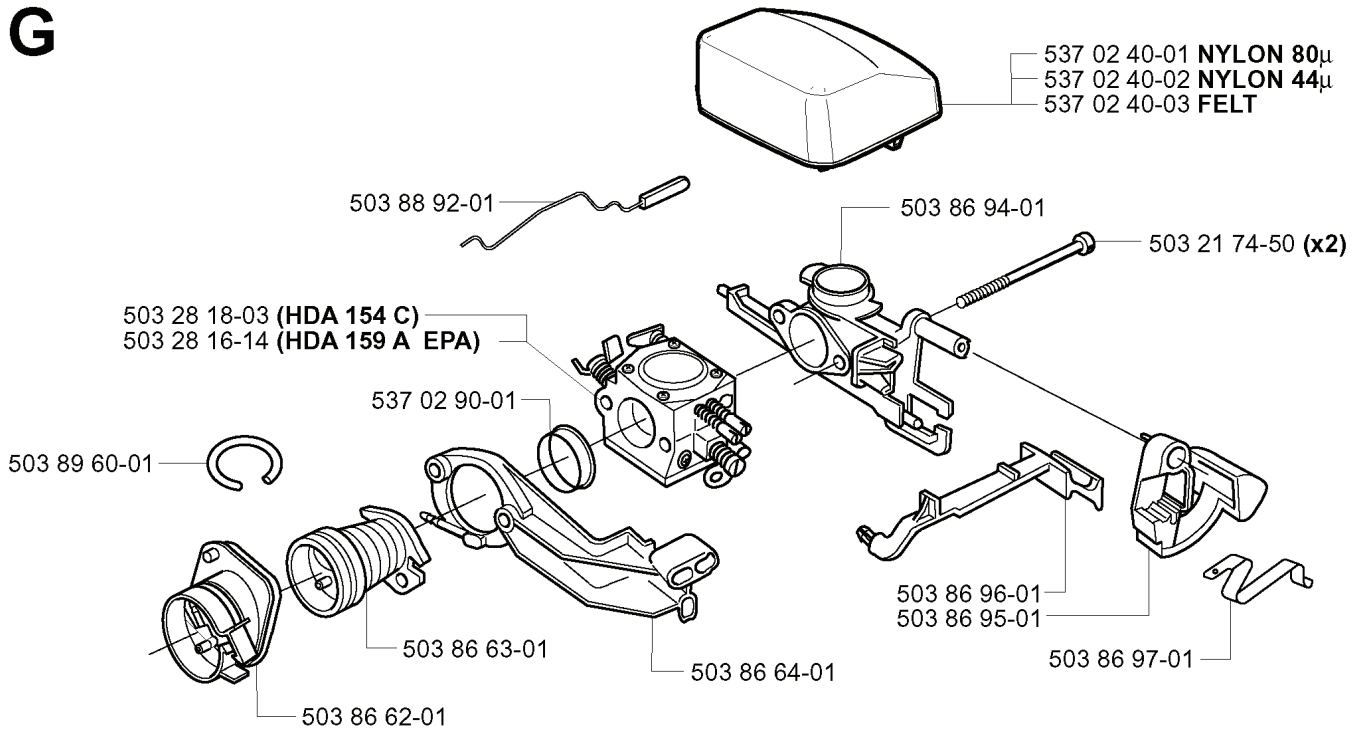

REF.	PART NO.	DESCRIPTION	REMARK	QTY.	KIT
503 88 92-01	503889201	THROTTLE ROD		1	
503 28 18-03	503281803	CARBURETTOR	HDA 154 C	1	
503 28 16-14	503281614	CARBURETTOR	HDA 159 A EPA	1	
503 89 60-01	503896001	IMPULSE HOSE		1	
503 86 62-01	503866201	INSULATION WALL		1	
503 86 63-01	503866301	BELLOWS		1	
537 02 90-01	537029001	SUPPORT RING		1	
503 86 64-01	503866401	FLANGE		1	
503 86 97-01	503869701	SHORT CIRCUIT SPRING		1	
503 86 95-01	503869501	STOP CONTROL		1	
503 86 96-01	503869601	CHOKE CONTROL		1	
503 21 74-50	503217450	SCREW IHSCT		2	
503 86 94-01	503869401	INLET BEND		1	
537 02 40-03	537024003	AIR FILTER	FELT	1	
537 02 40-02	537024002	AIR FILTER	NYLON	1	
537 02 40-01	537024001	AIR FILTER	NYLON	1	

J *compl 503 86 37-71

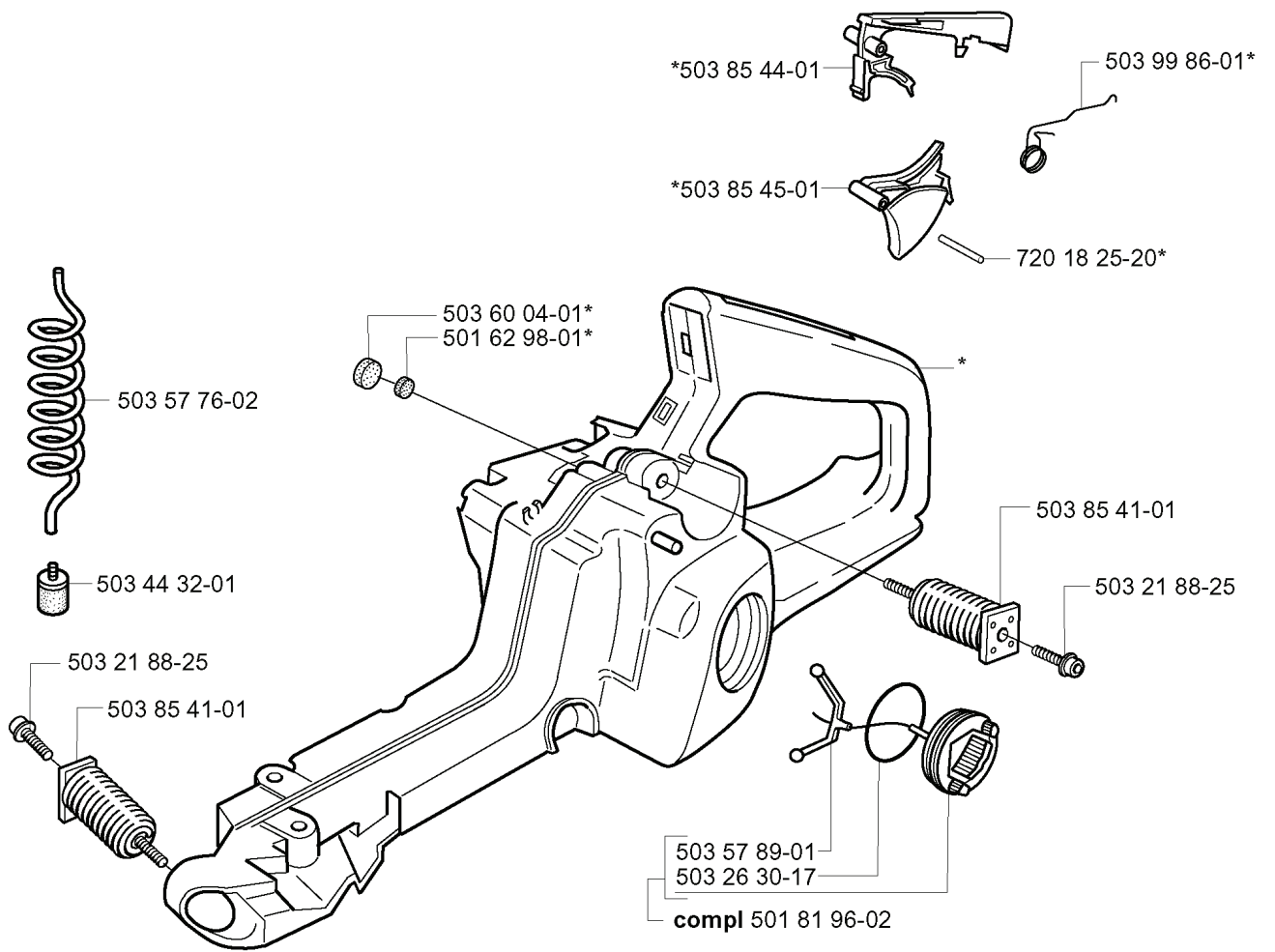

REF.	PART NO.	DESCRIPTION	REMARK	QTY.	KIT
503 86 37-71	503863771	FUEL TANK		1	
503 57 76-02	503577602	FUEL HOSE		1	
503 44 32-01	503443201	FUEL FILTER		1	
503 21 88-25	503218825	SCREW IHSCFT		1	
503 85 41-01	503854101	ANTIVIBRATION ELEMENT		1	
501 62 98-01	501629801	VALVE PLUG		1	
503 60 04-01	503600401	FILTER PLUG		1	
503 85 45-01	503854501	TRIGGER		1	
503 85 44-01	503854401	THROTTLE LOCKOUT		1	
503 57 89-01	503578901	HOLDER		1	
503 26 30-17	503263017	O-RING		1	
501 81 96-02	501819602	TANK CAP ASSY		1	
720 18 25-20	720182520	PARALLEL PIN		1	
503 99 86-01	503998601	RECOIL SPRING		1	

A

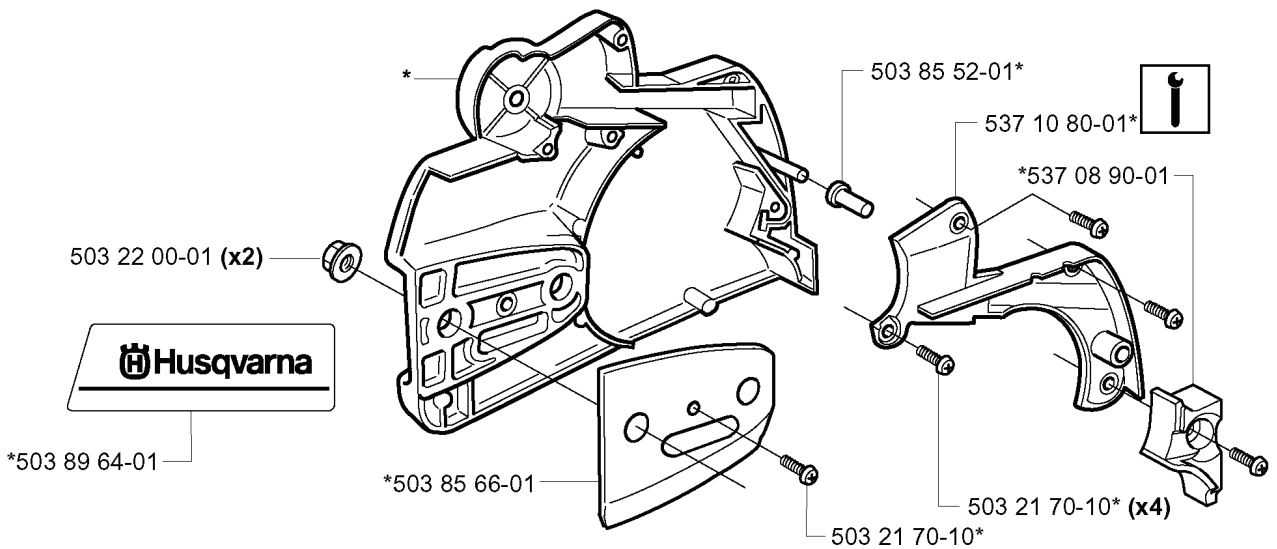
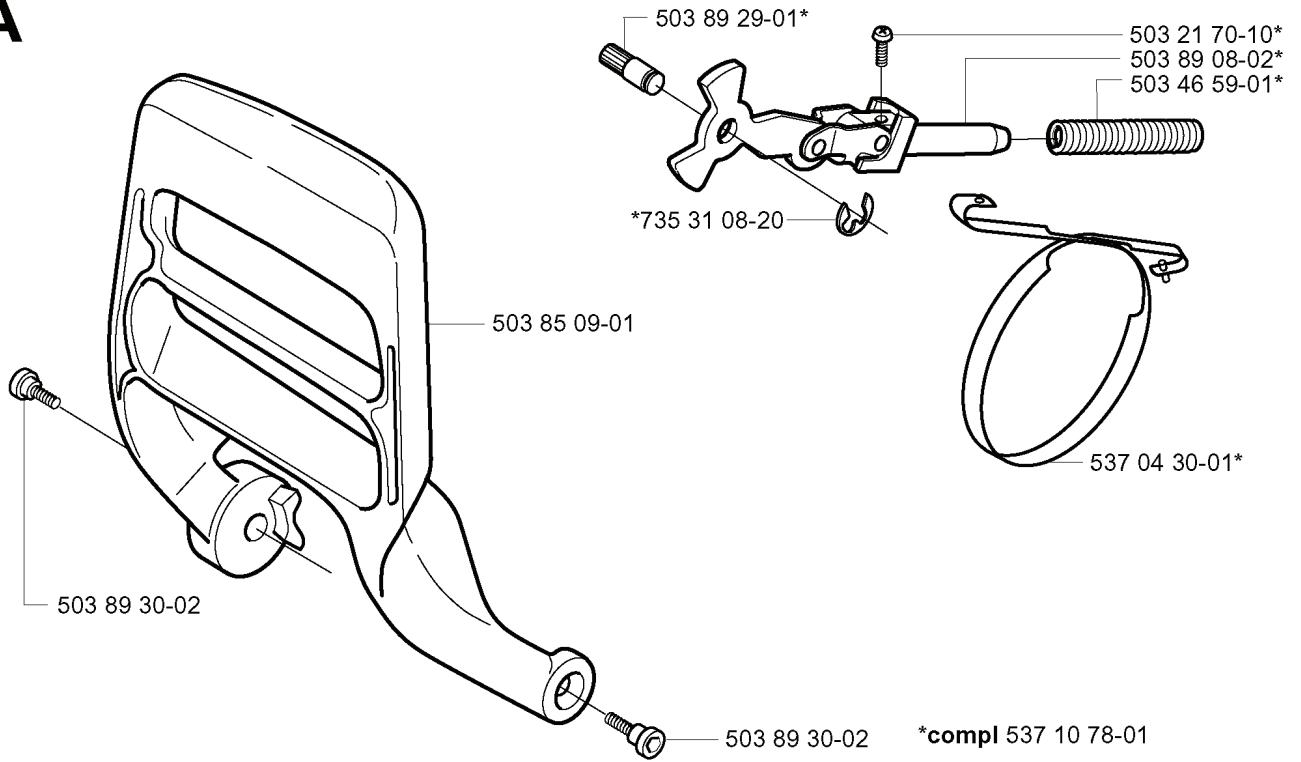

REF.	PART NO.	DESCRIPTION	REMARK	QTY.	KIT
503 22 00-01	503220001	HEXAGON NUT		2	
503 89 64-01	503896401	LABEL		1	
503 85 66-01	503856601	COVER PLATE		1	
537 08 90-01	537089001	WEAR PROTECTION		1	
537 10 80-01	537108001	HUB CAP		1	
503 85 52-01	503855201	GUIDE BUSHING		1	
537 10 78-01	537107801	CHAIN BRAKE		1	
503 89 30-02	503893002	SCREW		1	
503 85 09-01	503850901	HAND GUARD		1	
735 31 08-20	735310820	E-CLIP		1	
503 89 29-01	503892901	PIN		1	
537 04 30-01	537043001	BRAKE BAND ASSY		1	
503 46 59-01	503465901	BRAKE SPRING		1	
503 89 08-02	503890802	KNEE JOINT ASSY		1	
503 21 70-10	503217010	SCREW CCRPANT		1	

E *compl 503 85 80-71

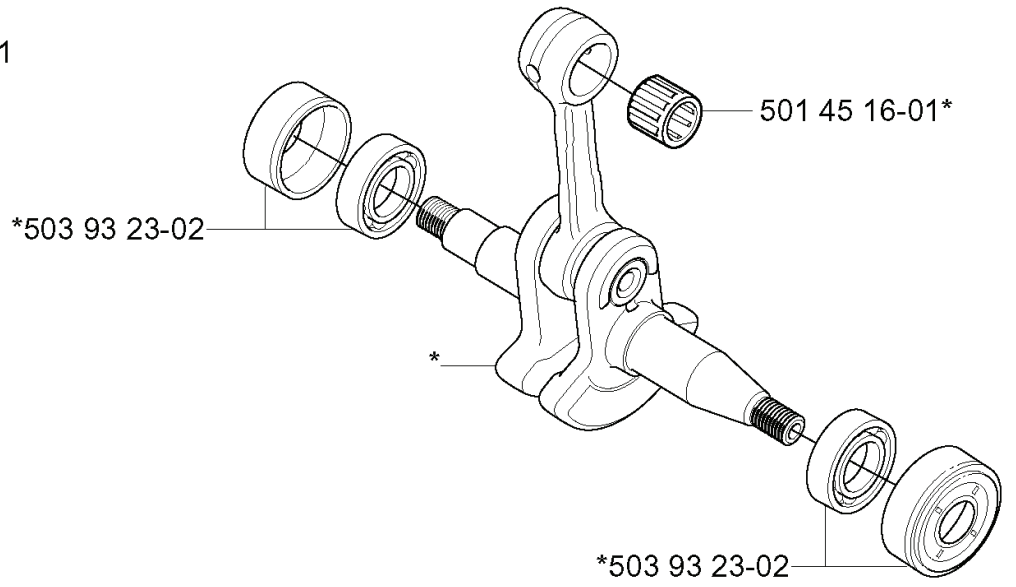

REF.	PART NO.	DESCRIPTION	REMARK	QTY.	KIT
503 85 80-71	503858071	CRANKSHAFT		1	
503 93 23-02	503932302	BEARING CAGE		1	
501 45 16-01	501451601	NEEDLE BEARING		1	

B

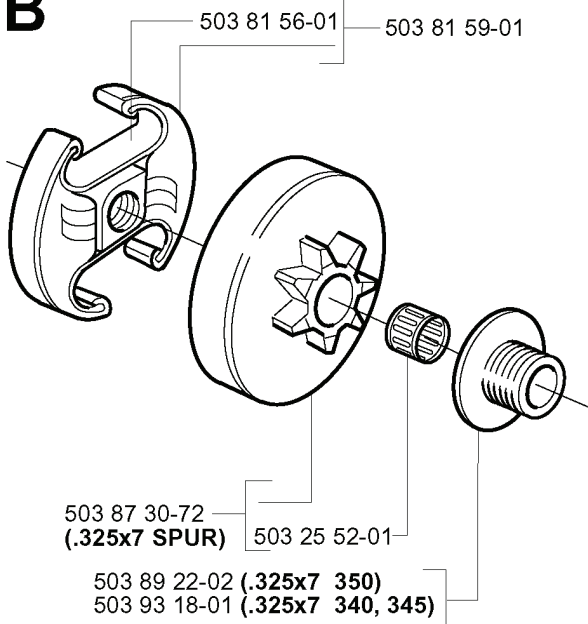

*compl 537 10 55-01 (350)

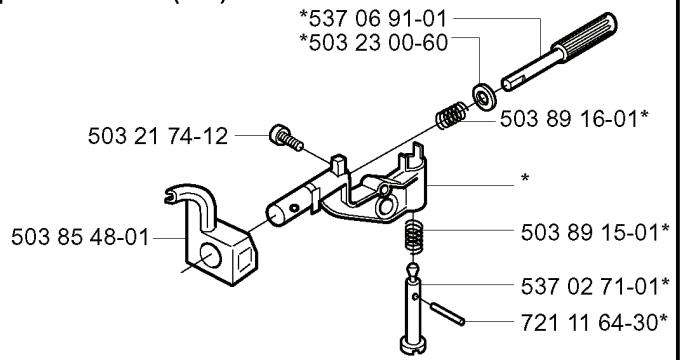

340, 345

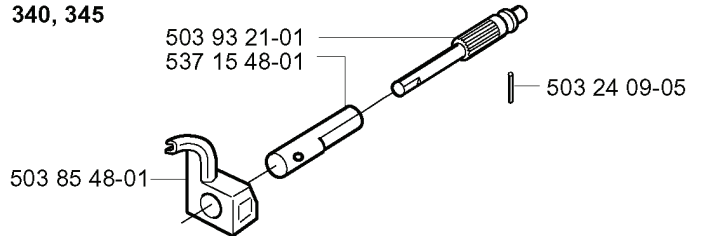

REF.	PART NO.	DESCRIPTION	REMARK	QTY.	KIT
503 81 56-01	503815601	CLUTCH SPRING		1	
503 87 30-72	503873072	CLUTCH DRUM ASSY	.325X7 SPUR	1	
503 89 22-02	503892202	PUMP PINION	.325X7 350	1	
503 93 18-01	503931801	PUMP PINION	.325X7 340, 345	1	
503 25 52-01	503255201	NEEDLE BEARING		1	
503 85 48-01	503854801	SEALING		1	
537 15 48-01	537154801	PUMP CYLINDER		1	
503 93 21-01	503932101	PUMP PISTON		1	
503 21 74-12	503217412	SCREW IHSCT		1	
537 10 55-01	537105501	OIL PUMP	350	1	
537 06 91-01	537069101	PUMP PISTON		1	
503 23 00-60	503230060	WASHER		1	
503 24 09-05	503240905	NEEDLE ROLLER		1	
721 11 64-30	721116430	GROOVED PIN		1	
537 02 71-01	537027101	ADJUSTER		1	
503 89 15-01	503891501	SPRING		1	
503 89 16-01	503891601	SPRING		1	

H *compl 537 17 20-01

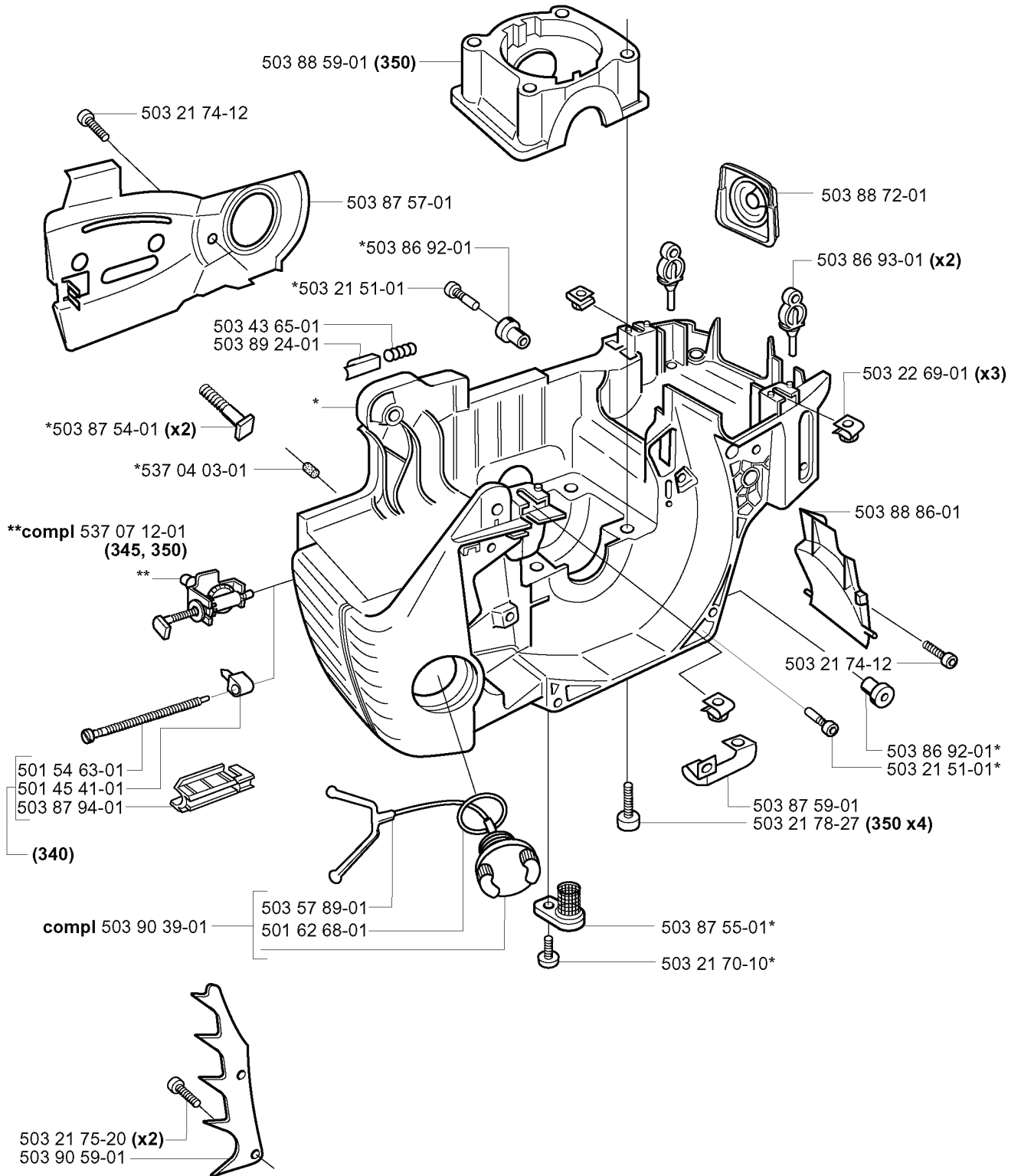

REF.	PART NO.	DESCRIPTION	REMARK	QTY.	KIT
537 17 20-01	537172001	CRANKCASE ASSY		1	
503 88 59-01	503885901	BEARING COVER	350	1	
503 87 57-01	503875701	CHAIN GUIDE PLATE		1	
503 86 92-01	503869201	BUSHING		1	
503 43 65-01	503436501	POSITION SPRING		1	
503 89 24-01	503892401	LOCK		1	
503 87 54-01	503875401	BAR BOLT		2	
537 04 03-01	537040301	VALVE		1	
537 07 12-01	537071201	CHAIN TENSIONER	345, 350	1	
501 54 63-01	501546301	SCREW	340	1	
501 45 41-01	501454101	NUT	340	1	
503 87 94-01	503879401	RETAINER	340	1	
503 90 39-01	503903901	TANK		1	
503 21 75-20	503217520	SCREW IHSCFT		2	
503 90 59-01	503905901	SPIKE		1	
501 62 68-01	501626801	GASKET		1	
503 57 89-01	503578901	HOLDER		1	
503 21 70-10	503217010	SCREW CCRPANT		1	
503 87 55-01	503875501	OIL SCREEN		1	
503 21 78-27	503217827	SCREW IHSCFT	350 X4	1	
503 87 59-01	503875901	GROUND PLATE		1	
503 21 51-01	503215101	SCREW IHSCFT		1	
503 21 74-12	503217412	SCREW IHSCFT		1	
503 88 86-01	503888601	AIR NOZZLE		1	
503 22 69-01	503226901	NUT		3	
503 86 93-01	503869301	SUPPORT		2	
503 88 72-01	503887201	BELLOWS		1	

K 503 85 37-01 (340, 345)

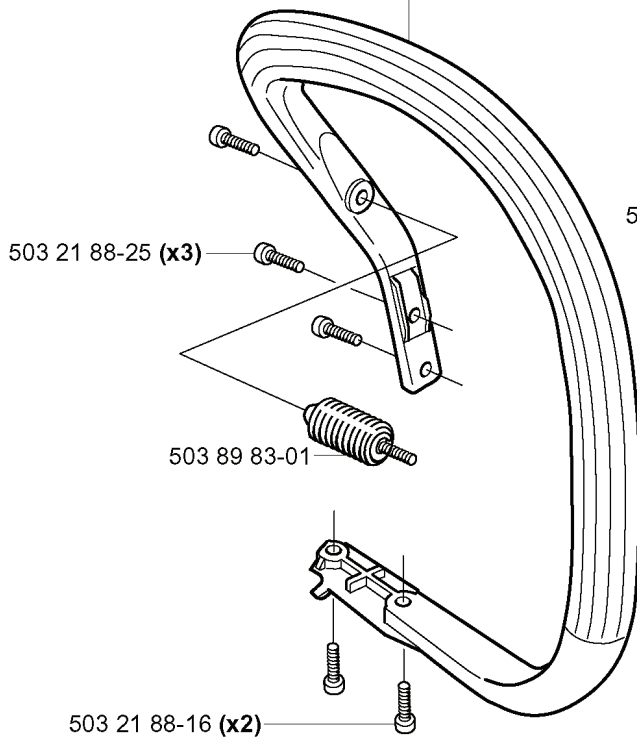

503 90 93-01 (350)

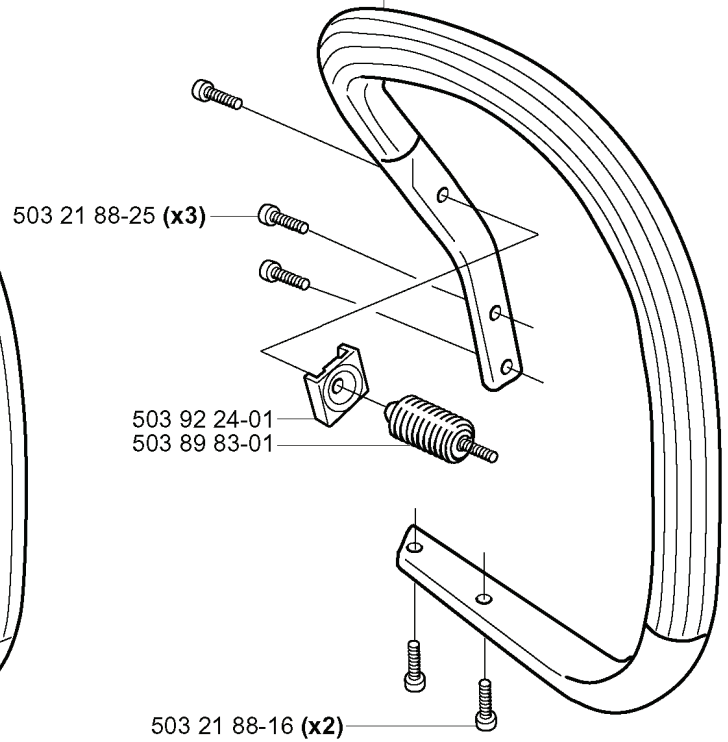

REF.	PART NO.	DESCRIPTION	REMARK	QTY.	KIT
503 85 37-01	503853701	FRONT HANDLE	340, 345	1	
503 21 88-25	503218825	SCREW IHSCFT		3	
503 89 83-01	503898301	ANTIVIBRATION ELEMENT		1	
503 21 88-16	503218816	SCREW IHSCFT		2	
503 92 24-01	503922401	SPACER		1	
503 90 93-01	503909301	HANDLE	350	1	

REF.	PART NO.	DESCRIPTION	REMARK	QTY.	KIT
537 10 47-01	537104701	STARTER ASSY		1	
503 89 06-01	503890601	AIR CONDUCTOR		1	
503 21 77-16	503217716	SCREW IHSCT		1	
503 21 29-10	503212910	SCREW CCRPANT		2	
537 10 27-01	537102701	STARTER HOUSING		1	
503 91 04-02	503910402	LABEL	350	1	
503 91 04-01	503910401	LABEL	345	1	
503 91 04-07	503910407	LABEL	340	1	
537 09 31-01	537093101	SPRING CASSETTE ASSY		1	
537 09 25-01	537092501	STARTER PULLEY		1	
505 30 51-25	505305125	STARTER ROPE		1	
501 63 06-01	501630601	SLEEVE		1	
503 21 73-21	503217321	SCREW		4	
503 54 39-01	503543901	STARTER HANDLE		1	

C *compl 503 91 05-01

*503 98 74-01

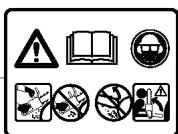

*503 20 34-25 (x3)

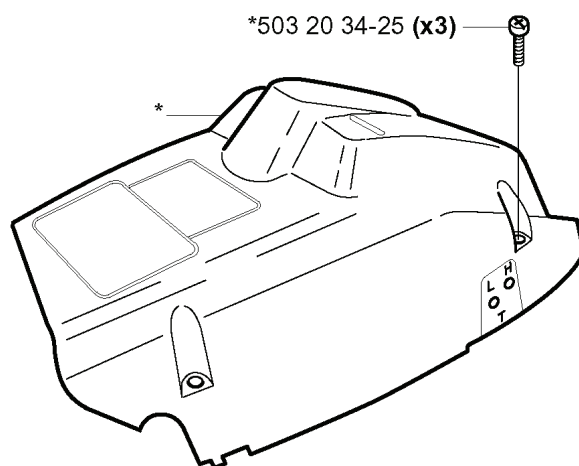

F

*compl 503 86 27-02 (EU) 350

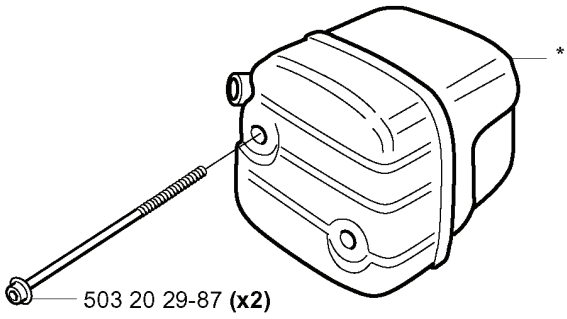

*compl 503 87 96-01 (FG) 340, 345

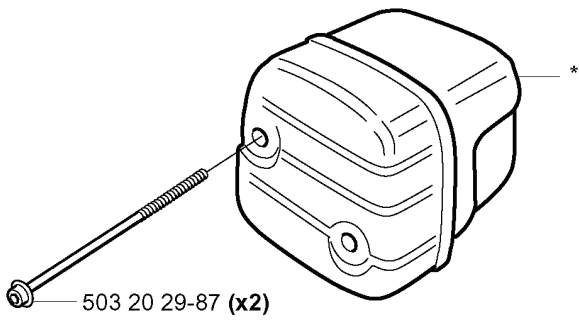

*compl 503 86 28-02 (DF) 340, 345, 350

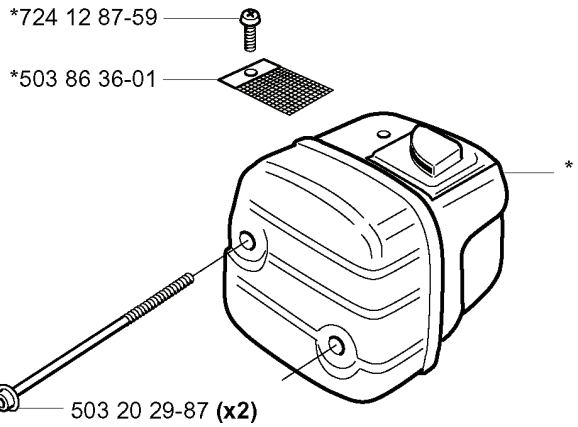

REF.	PART NO.	DESCRIPTION	REMARK	QTY.	KIT
503 86 27-02	503862702	MUFFLER ASSY	EU 350	1	
503 87 96-01	503879601	MUFFLER ASSY	FG 340, 345	1	
503 20 29-87	503202987	SCREW IHSCFM		2	
503 86 36-01	503863601	SPARK ARRESTER SCREEN		1	
724 12 87-59	724128759	SCREW CRPANM		1	
503 86 28-02	503862802	MUFFLER ASSY	DF 340, 345, 350	1	

P Tillbehör
Accessories
Zubehöre
Accessoires
Accesorios

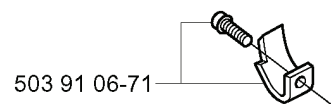
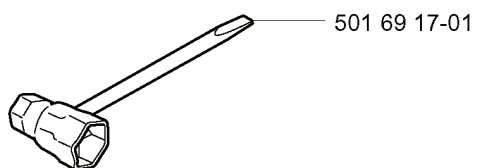

Winter kit

*compl 537 04 28-71

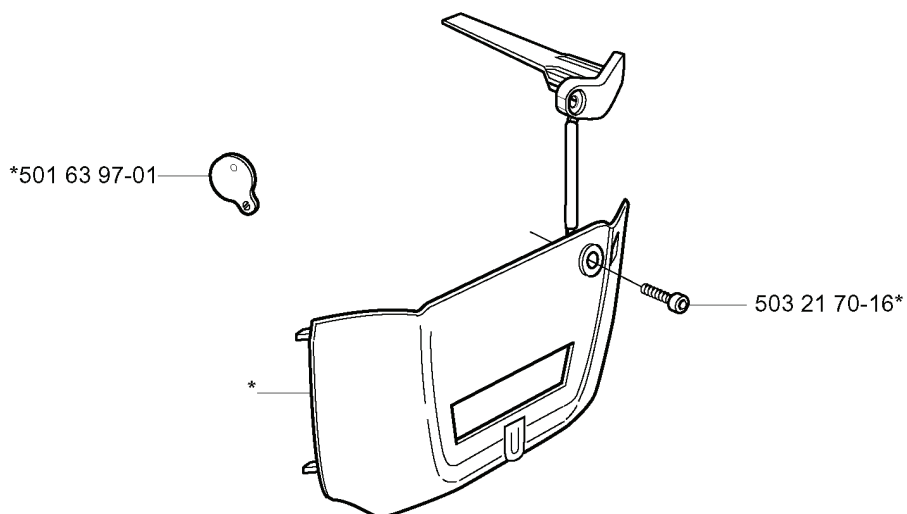

REF.	PART NO.	DESCRIPTION	REMARK	QTY.	KIT
537 04 28-71	537042871	KIT		1	
501 63 97-01	501639701	COVER		1	
503 21 70-16	503217016	SCREW CCRPANT		1	
503 91 06-71	503910671	KIT		1	
501 69 17-01	501691701	COMBINATION WRENCH		1	

N *compl 503 28 18-03 Walbro HDA 154 C
 **compl 503 28 16-14 Walbro HDA 159 A (EPA)

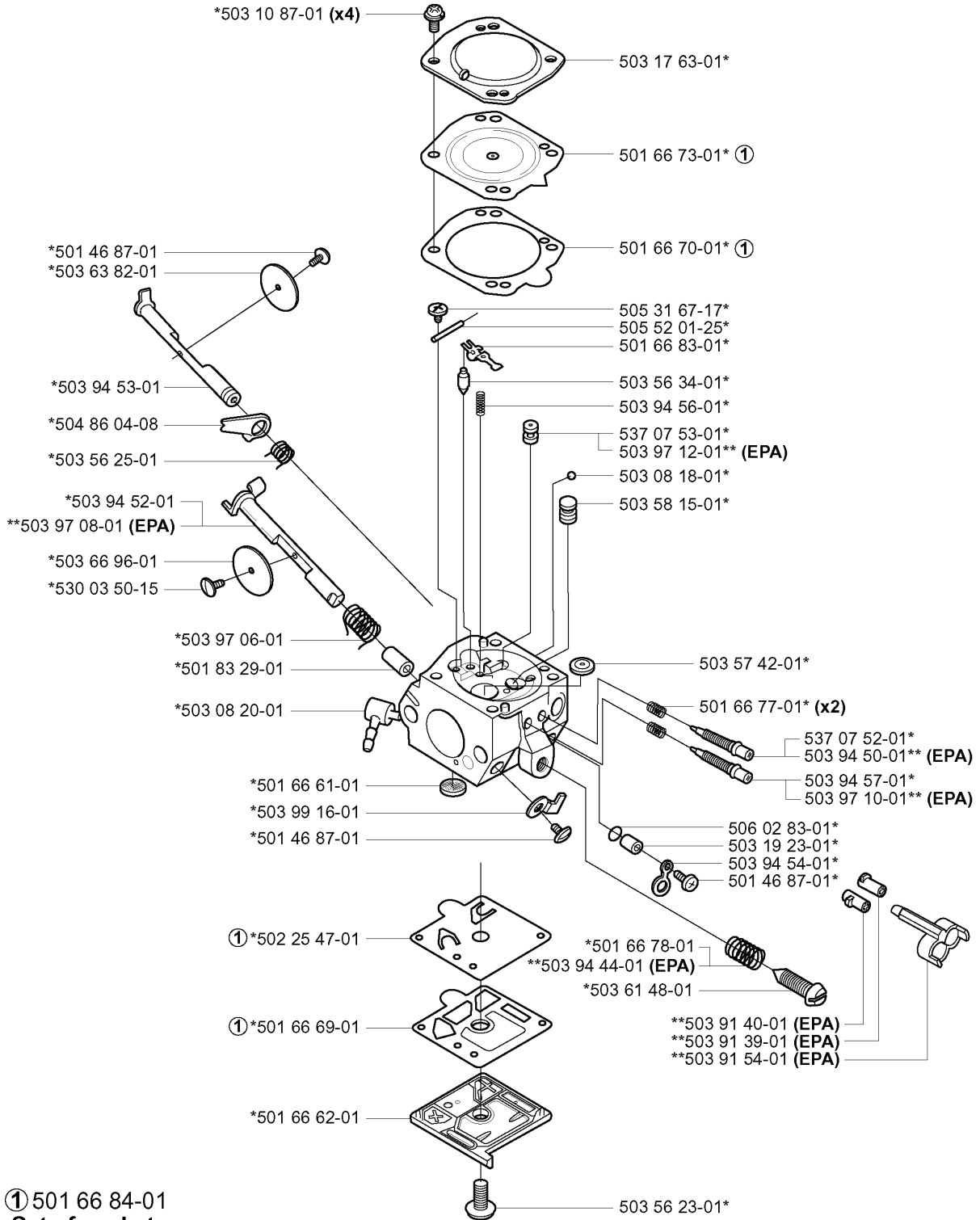

① 501 66 84-01
Set of gaskets
Dichtungssatz
Jeu de joints
Juego de juntas
Packningssats

REF.	PART NO.	DESCRIPTION	REMARK	QTY.	KIT
503 28 18-03	503281803	CARBURETTOR	WALBRO HDA 154 C	1	
503 28 16-14	503281614	CARBURETTOR	WALBRO HDA 159 A (EPA)	1	
503 10 87-01	503108701	SCREW		4	
503 63 82-01	503638201	VALVE CHOKE		1	
503 94 53-01	503945301	SHAFT ASSY		1	
504 86 04-08	504860408	LEVER		1	
503 56 25-01	503562501	SPRING		1	
503 94 52-01	503945201	SHAFT ASSY		1	
501 66 84-01	501668401	GASKET KIT		1	
503 97 08-01	503970801	SHAFT ASSY	EPA	1	
503 66 96-01	503669601	VALVE THROTTLE		1	
530 03 50-15	530035015	SCREW		1	
503 97 06-01	503970601	SPRING		1	
501 83 29-01	501832901	BUSHING		1	
503 08 20-01	503082001	FITTING		1	
501 66 61-01	501666101	SCREEN		1	
503 99 16-01	503991601	LEVER		1	
502 25 47-01	502254701	DIAPHRAGM PUMP	501 66 84-01 SET OF GASKETS	1	
501 66 69-01	501666901	GASKET	501 66 84-01 SET OF GASKETS	1	
501 66 62-01	501666201	COVER		1	
503 56 23-01	503562301	SCREW		1	
503 91 54-01	503915401	RETAINER	EPA	1	
503 91 39-01	503913901	LIMITER CAP	EPA	1	
503 91 40-01	503914001	LIMITER CAP	EPA	1	
503 61 48-01	503614801	SCREW		1	
503 94 44-01	503944401	SPRING	EPA	1	
501 66 78-01	501667801	SPRING		1	
501 46 87-01	501468701	SCREW		1	
503 94 54-01	503945401	LEVER		1	
503 19 23-01	503192301	SPACER-SHAFT-CHOKE		1	
506 02 83-01	506028301	WASHER		1	
503 97 10-01	503971001	NEEDLE	EPA	1	
503 94 57-01	503945701	NEEDLE		1	
503 94 50-01	503945001	NEEDLE	EPA	1	
537 07 52-01	537075201	NEEDLE		1	
501 66 77-01	501667701	SPRING		2	
503 57 42-01	503574201	PLUG		1	
503 58 15-01	503581501	NOZZLE ASSY		1	
503 08 18-01	503081801	PLUG		1	
503 97 12-01	503971201	JET	EPA	1	
537 07 53-01	537075301	JET		1	

REF.	PART NO.	DESCRIPTION	REMARK	QTY.	KIT
5039456-01	503945601	SPRING		1	
5035634-01	503563401	NEEDLE VALVE		1	
5016683-01	501668301	LEVER		1	
5055201-25	505520125	PIN		1	
5053167-17	505316717	SCREW		1	
5016670-01	501667001	GASKET	5016684-01 SET OF GASKETS	1	
5016673-01	501667301	DIAPHRAGM	5016684-01 SET OF GASKETS	1	
5031763-01	503176301	COVER		1	

D

*compl 503 87 00-73 (340)

*compl 503 87 02-74 (345)

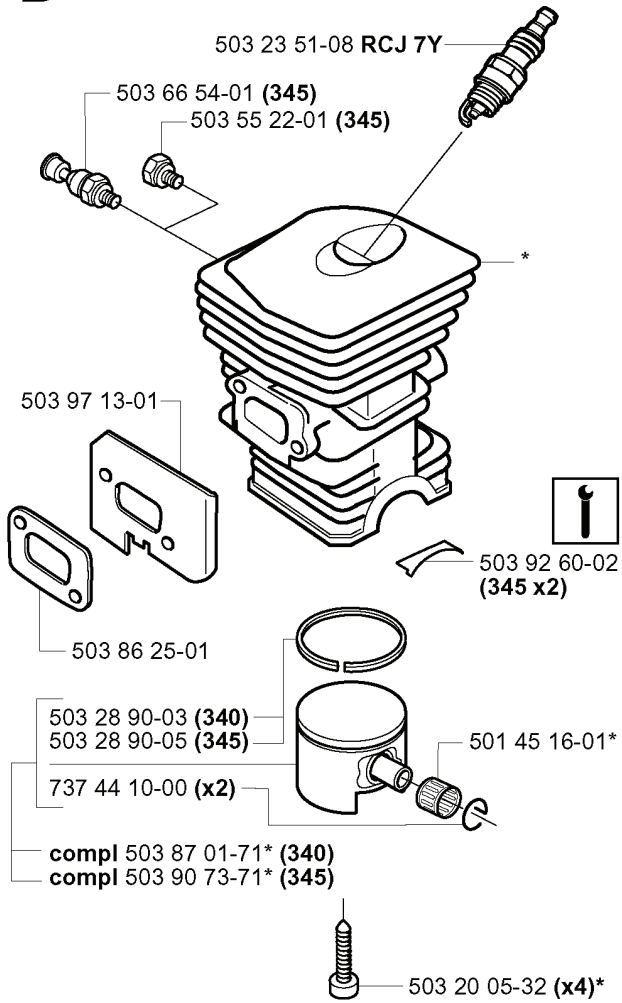

*compl 503 86 99-71 (350)

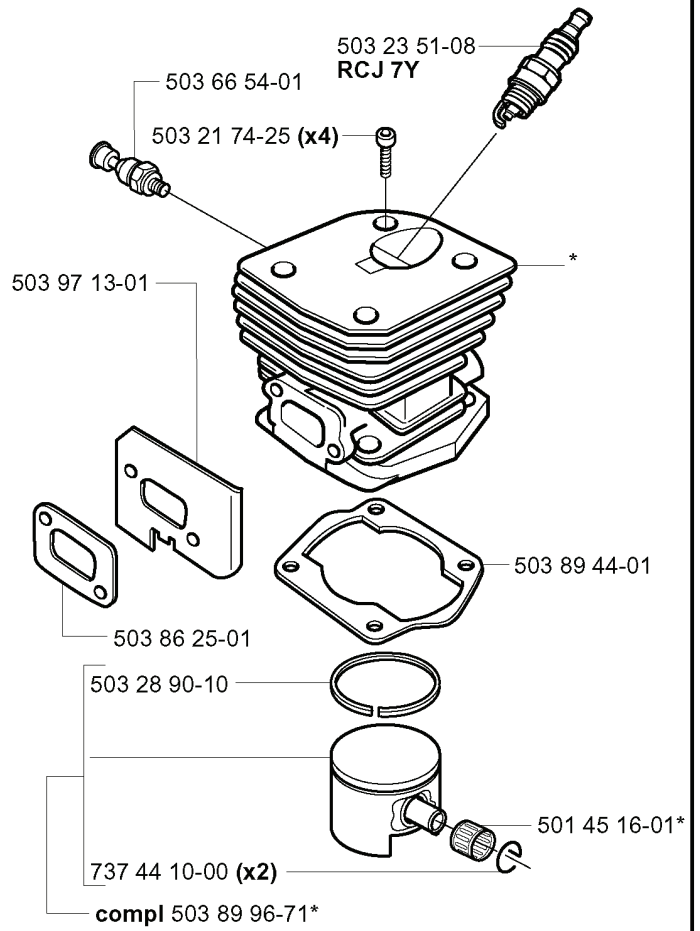

REF.	PART NO.	DESCRIPTION	REMARK	QTY.	KIT
503 87 00-73	503870073	CYLINDER ASSY	340	1	
503 87 02-74	503870274	CYLINDER ASSY	345	1	
503 21 74-25	503217425	SCREW IH SCT		1	
503 23 51-08	503235108	SPARK PLUG	RCJ 7Y	1	
503 66 54-01	503665401	DECOMPRESSION VALVE	345	1	
503 55 22-01	503552201	PLUG	345	1	
503 28 90-10	503289010	PISTON RING		1	
503 97 13-01	503971301	HEAT DEFLECTOR		1	
503 86 25-01	503862501	GASKET		1	
503 28 90-03	503289003	PISTON RING	340	1	
503 28 90-05	503289005	PISTON RING	345	1	
737 44 10-00	737441000	SNAP RING		2	
503 86 99-71	503869971	CYLINDER ASSY		1	
503 87 01-71	503870171	PISTON ASSY	340	1	
503 90 73-71	503907371	PISTON ASSY	345	1	
503 20 05-32	503200532	SCREW IH SCM		4	
503 89 44-01	503894401	GASKET		1	
501 45 16-01	501451601	NEEDLE BEARING		1	
503 89 96-71	503899671	PISTON ASSY		1	
503 92 60-02	503926002	COVER PLATE	345 X2	1	

L

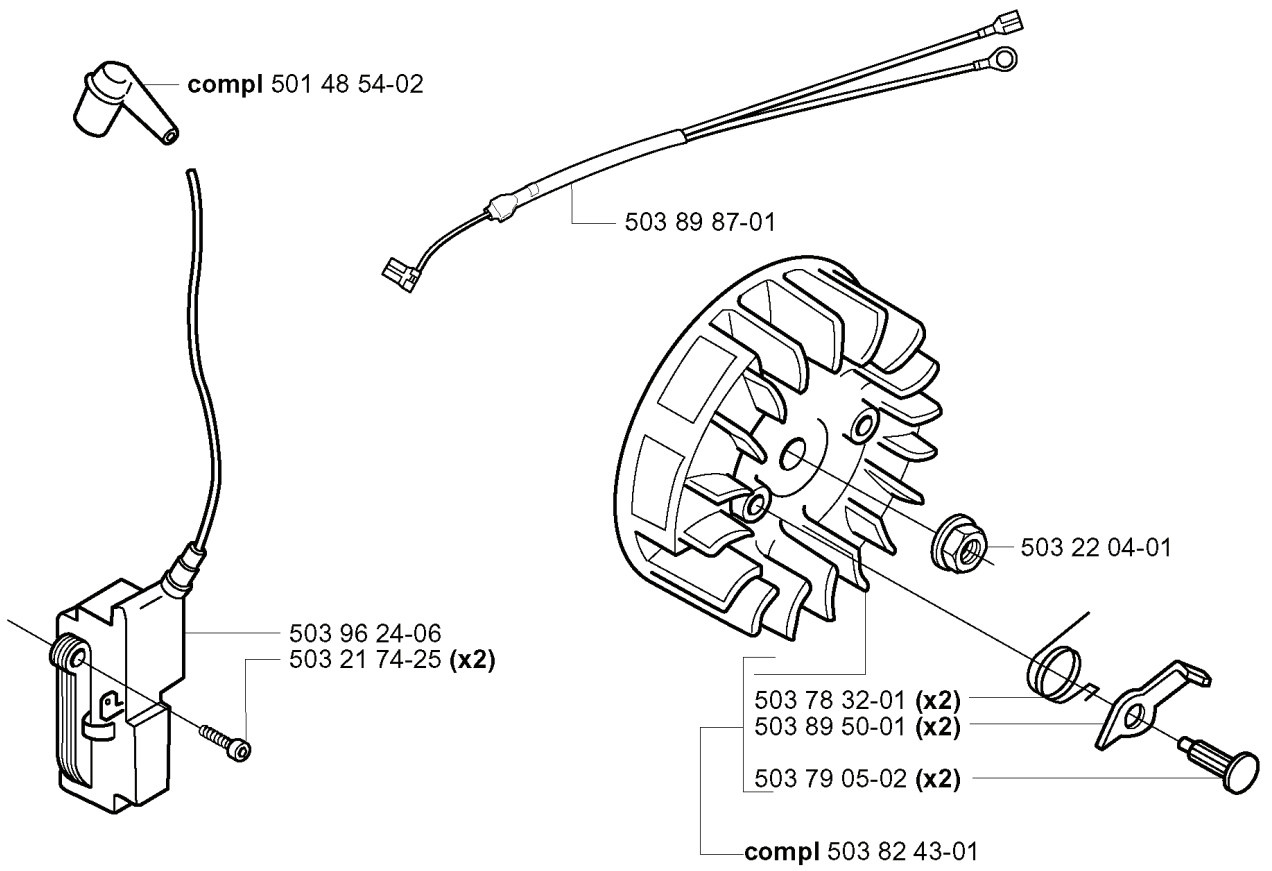

REF.	PART NO.	DESCRIPTION	REMARK	QTY.	KIT
5014854-02	501485402	SPARK PLUG CAP		1	
5039624-06	503962406	ELECTRONIC MODULE		1	
5032174-25	503217425	SCREW IHSCT		2	
5038243-01	503824301	FLYWHEEL		1	
5037905-02	503790502	RIVET		2	
5038950-01	503895001	STARTER PAWL		2	
5037832-01	503783201	SPRING		2	
5032204-01	503220401	NUT		1	
5038987-01	503898701	WIRING ASSY		1	
	PART NO.		REMARK		KIT