

## **Husqvarna's new demolition robot — lightweight machine that packs a real punch**

*Compact design, a powerful punch and perfect for demolition work in restricted spaces. Husqvarna is now launching another machine, the DXR 250, in its new range of remote-controlled demolition robots.*

*"This is the most powerful machine in its size class on the market," says Thomas Nilsson, Business Manager Demolition Equipment, Husqvarna Construction Products.*

Husqvarna launched its first remote-controlled demolition robot, the DXR 310, in 2009. So now it's time for number two in the new range. Just like the 310, the DXR 250 has been developed with a clear user focus. Its weight-to-power ratio has been optimised to make it both powerful and lightweight. A fixed arm makes the machine compact and contributes to its low weight of 1620 kg. Its low-slung body gives the operator a free view over the machine when working, making his work more efficient and safer.

"We have developed our new robot because we know there is a demand for a machine in this size class. The DXR 250 is compact and flexible to operate, it weighs only 1620 kg and has an output of 18.5 kilowatts. There is also a 22 kW option," says Thomas Nilsson, Business Manager Demolition Equipment, Husqvarna Construction Products.

The baseplate of the DXR 250 is cast in a single piece for optimal weight distribution and balance. The plate includes parts such as fasteners, lifting loops and LED spotlights, giving it unrivalled durability and better light for working. It has practical dozer blades which make the chassis shorter and stabilise its construction. This makes the robot simpler to manoeuvre

in restricted spaces and to transport. Other technical innovations is an electrical fan, which gives efficient cooling, and electrical proportional control of the hydraulic pump, so that the machine pressure is efficiently controlled. The result is a machine of high efficiency and with minimised thermal losses.

Like the DXR 310, the robot is simple to service and maintain. Our newly developed remote control system with Bluetooth technology is the easiest to use on the market, with a clear plain-text display that shows when it's time for the various servicing jobs. The control system is adapted to handle tough demolition environments ▶

**Powerful punch.** *With a compact design and a powerful punch, the DXR 250 is perfect for demolition work in restricted spaces.*



- ▶ characterised by high vibrations, concrete dust and water. The DXR 250 is suitable for working with minor demolition, sensitive environments in applications such as the processing industry, interior work and demolition work in restricted spaces, such as pile-driving work.

The new robot will be unveiled at the World of Concrete in USA in February, and deliveries will start from the beginning of the same month.

And there is more to come. Husqvarna will already be launching another robot, the DXR 140, in time for spring.



**Compact.** A fixed arm makes the machine nibble and compact and contributes to its low weight of 1620 kg.

#### Technical facts about the DXR 250

- Cast baseplate assures optimal weight distribution
- The best power-to-weight ratio on the market with good stability and long range
- Compact low construction gives optimal view and manoeuvrability
- Simple to service and maintain
- Power: 18.5 kW, 22 kW
- Weight: 1620 kg
- Range: approx 4.5 meters
- Control system: Modular, digital CAN-based PLC
- Dimensions of body: length: 1695 mm, width: 780 mm height: 1035 mm
- Automatic hammer lubrication



**Multi-purpose.** The robot is equipped with practical dozer blades.

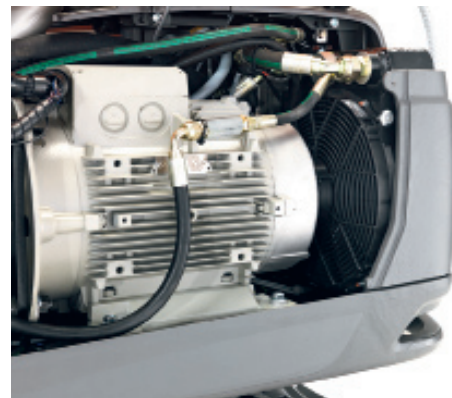

**Cool.** The electrical fan gives efficient cooling, and results in a machine of high efficiency.

#### For more information contact:

Thomas Nilsson, Business Manager Demolition Equipment, Husqvarna Construction Products

Tel: +46 (0)31-94 90 16, +46 (0)70-594 20 16

E-mail: [thomas.nilsson@husqvarna.se](mailto:thomas.nilsson@husqvarna.se)

---

Husqvarna Construction Products is part of Husqvarna AB and market leader in machinery and diamond tools for the construction and stone industries. The product range includes power cutters, diamond tools, drill motors and drill stands, wall and wire saws, floor saws, table saws as well as machines for surface preparation and demolition. Husqvarna Construction Products accounted for 25% of Husqvarna's sales of products for professional use in 2008. Construction Products has 2,300 employees, ten large factories around the world and is represented in more than 70 countries. Husqvarna is a registered trademark owned by Husqvarna AB (publ).

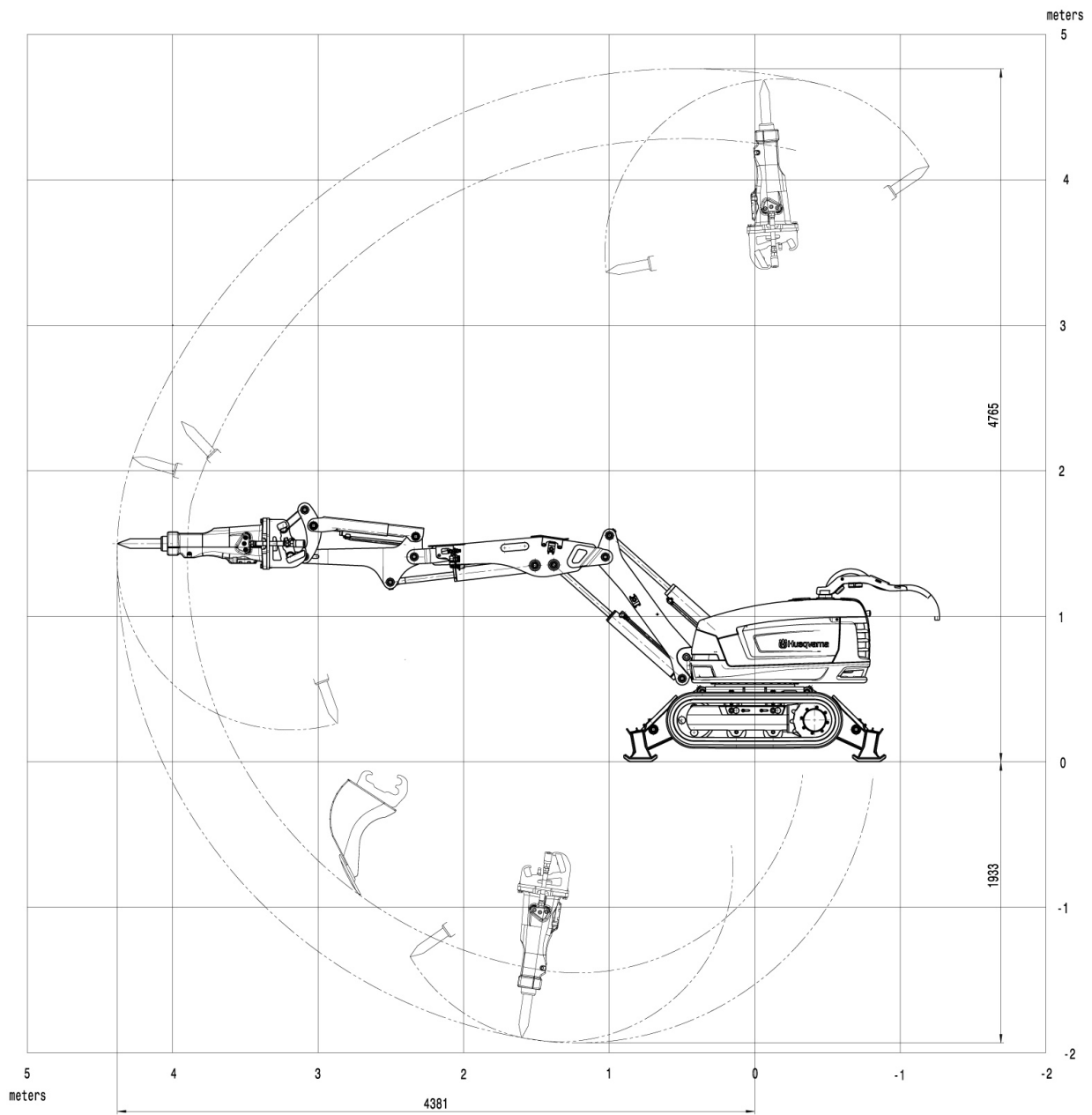

*Range, the DXR 250: approx. 4,5 meters.*

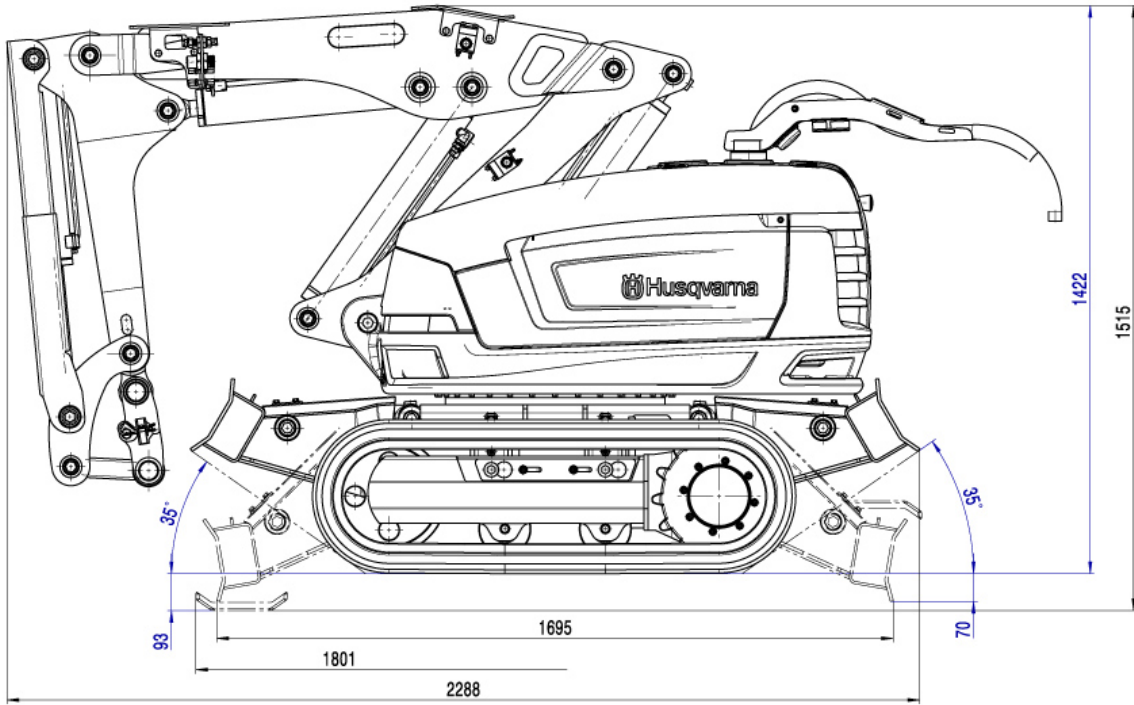

*The DXR 250, measurements.*

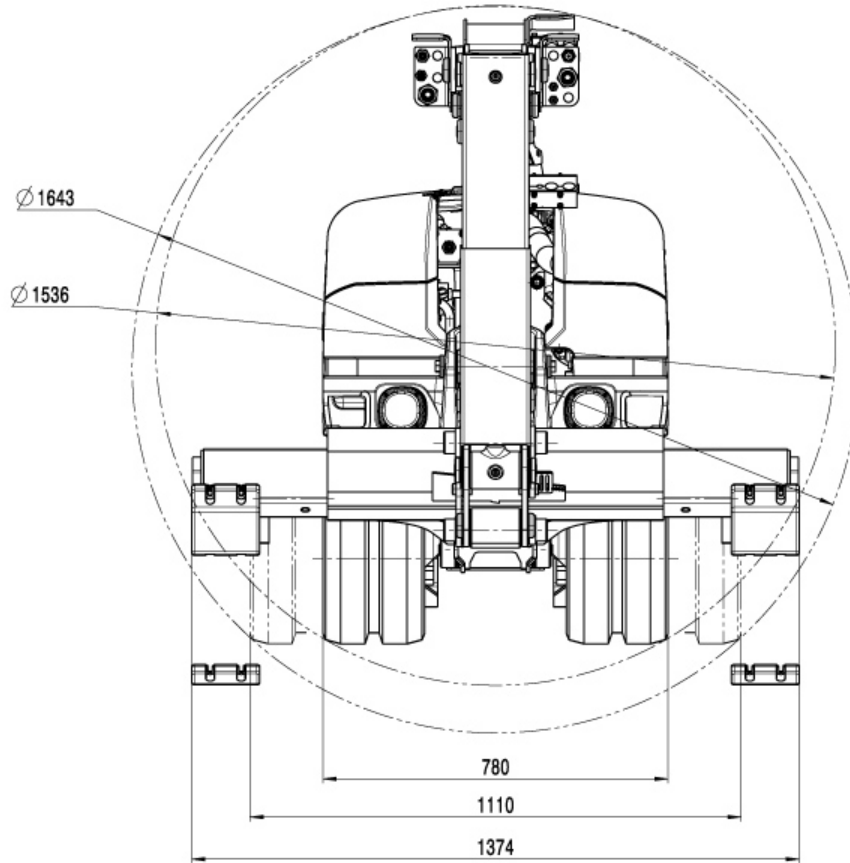

*The DXR 250, dimension of body, width: 780 mm.*